

KoPa Capture Pro Software User Manual



Content

Chapter 1: Software Installation.....	- 1 -
1.1 Environmental requirements for software installation	- 1 -
1.2 Installation steps	- 1-2 -
1.3 Software connection to the camera method	- 2-3 -
Chapter 2: Software Instructions	- 4 -
2.1 Operation interface	- 4 -
2.2 Shortcut toolbar	- 4 -
2.2.1 Shortcut tools	- 4-5 -
2.2.2 Automatic depth-of-field fusion function for high content images.....	- 5 -
2.2.3 Combine channels	- 6 -
2.2.4 Combined color images	- 6 -
2.3 Working mode bar	- 7 -
2.4 Camera property control	- 7 -
2.5 Measuring tools	- 8 -
2.5.1 Calibration	- 8-9 -
2.5.2 Select measurement tool for measurement	- 9-10 -
2.6 Drawing tools	- 10 -
2.7 Thumbnail toolbar	- 11 -
2.8 Software setup	- 11 -

1.1 Environmental requirements for software installation

System requirements:

CPU type: i5 10th Generation or later version;

Memory capacity ≥ 16GB or more;

Hard drive capacity ≥ 512GB or more;

System: Genuine Microsoft Windows 10 (64 bit) or later version;

Graphics card: Core display or discrete graphics card.

Note: Some functions in the software require the computer with

Microsoft Word 2003 or later version (for output measurement results to Microsoft Word function)

Microsoft Excel 2003 or later version (for output measurement results to Microsoft Excel function)

Microsoft Outlook 2003 or later version (for sending pictures via email function)

1.2 Installation steps

Step 1. Run the file “KoPa Capture Pro Install”. When window pops up, please select the installation guide language.

Note: The installation guide language is independent of the software interface language. If you need to change the software interface language, please select the "Language" function in the "Settings" menu to modify.

Step 2. When the window “Welcome to use KoPa Capture Pro Setup Wizard” pops up, please click the button “Next >”.

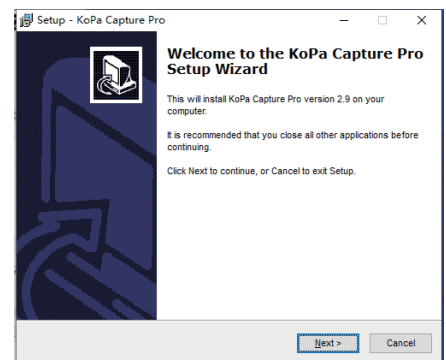

Step 3. When the window “Select Destination Location” pops up, click “Browse” to choose the file path for installation (usually default), and then click “Next >” to continue.

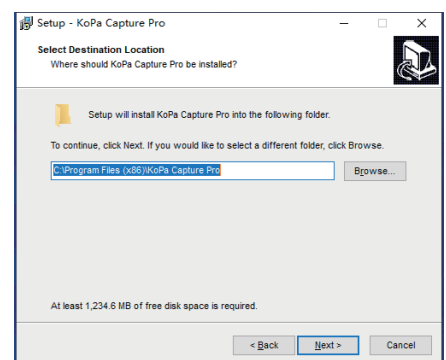

Step 4. When following window appears, select the shortcut you need, and then click the button “Next >”.

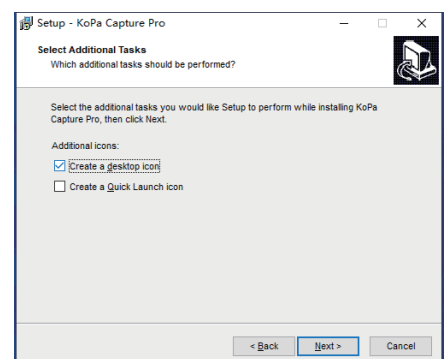

Step 5. Confirm information like the “Destination Location” of software installation. After confirmation, please click the button “Install”.

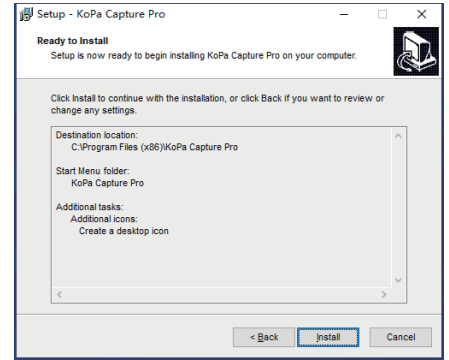

Step 6. An installation progress bar will appear during the software installation procedure. The software installation necessitates the registration of some runtime libraries, which might be intercepted by some antivirus software. If such interception pops up, please allow the procedure to continue.

Step 7. An installation progress bar will appear during the software installation procedure. When the following window appears, the software has been installed successfully. Then click the button “Finish” to complete the installation. After closing the window, check the icon “KoPa CAM” on your computer desktop. If you fail to find it, please find it from the path “Start” → “All programs”.

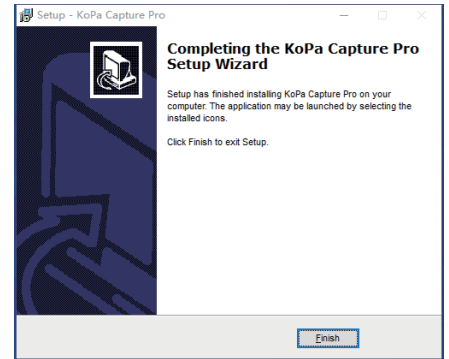

1.3 Software connection to the camera method

The software supports connection to the camera via USB, WiFi and network connections.

1.3.1 USB connection method

Just unplug the camera switch to USB gear and connect the camera USB cable to the PC's USB port.

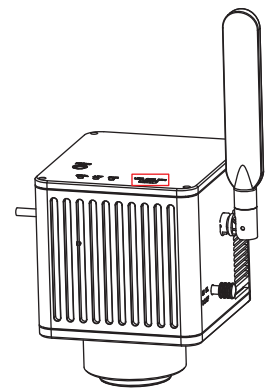
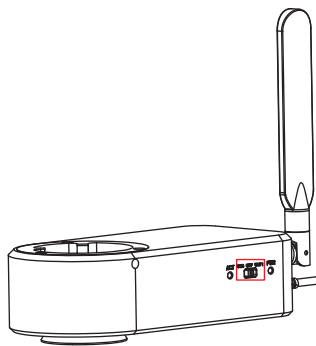
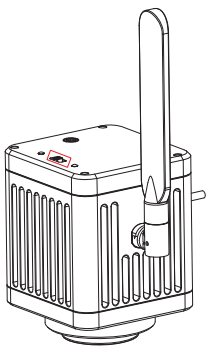

1.3.2 Wireless connection method (only valid for cameras with WiFi capability)

Step 1: Confirm that the computer supports the 5G WiFi IEE 802.11ac protocol;

Step 2: WiFi embedded camera or WiFi camera, power on and switch to WiFi gear. As shown in the figure below:

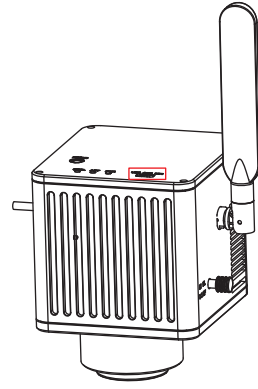
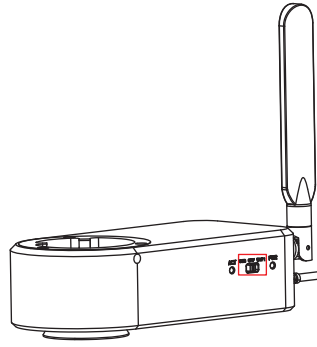
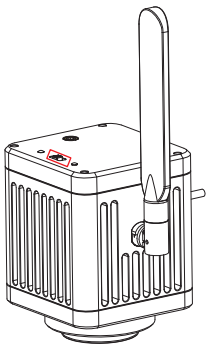

If you are using a smart embedded display camera, smart display camera, smart embedded camera, smart camera, you only need to turn on the power.

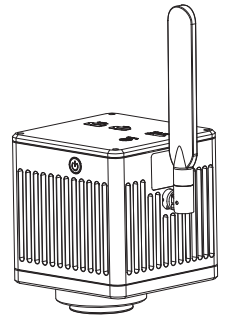
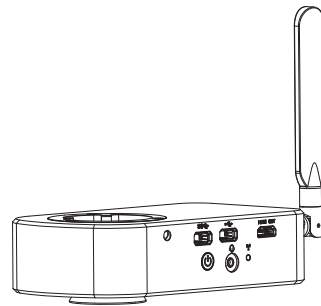
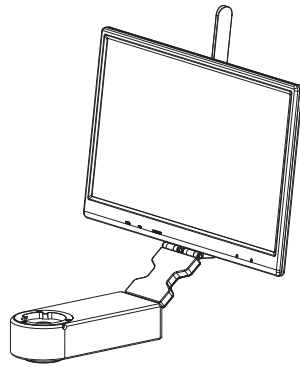
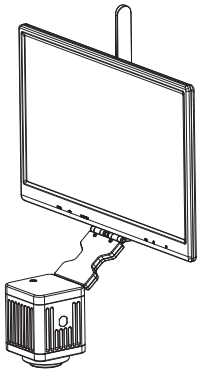

Step 3: After the WiFi camera is started, search for the camera's WiFi name WiFiCamera_5G_XXXXXX or WiFi5Camera_XXXXXX in the network connection, the default connection password is 12345678, the display shows "Connected" that is successfully connect-ed to the camera WiFi, start the software to get real-time images.

2.1 Operation interface

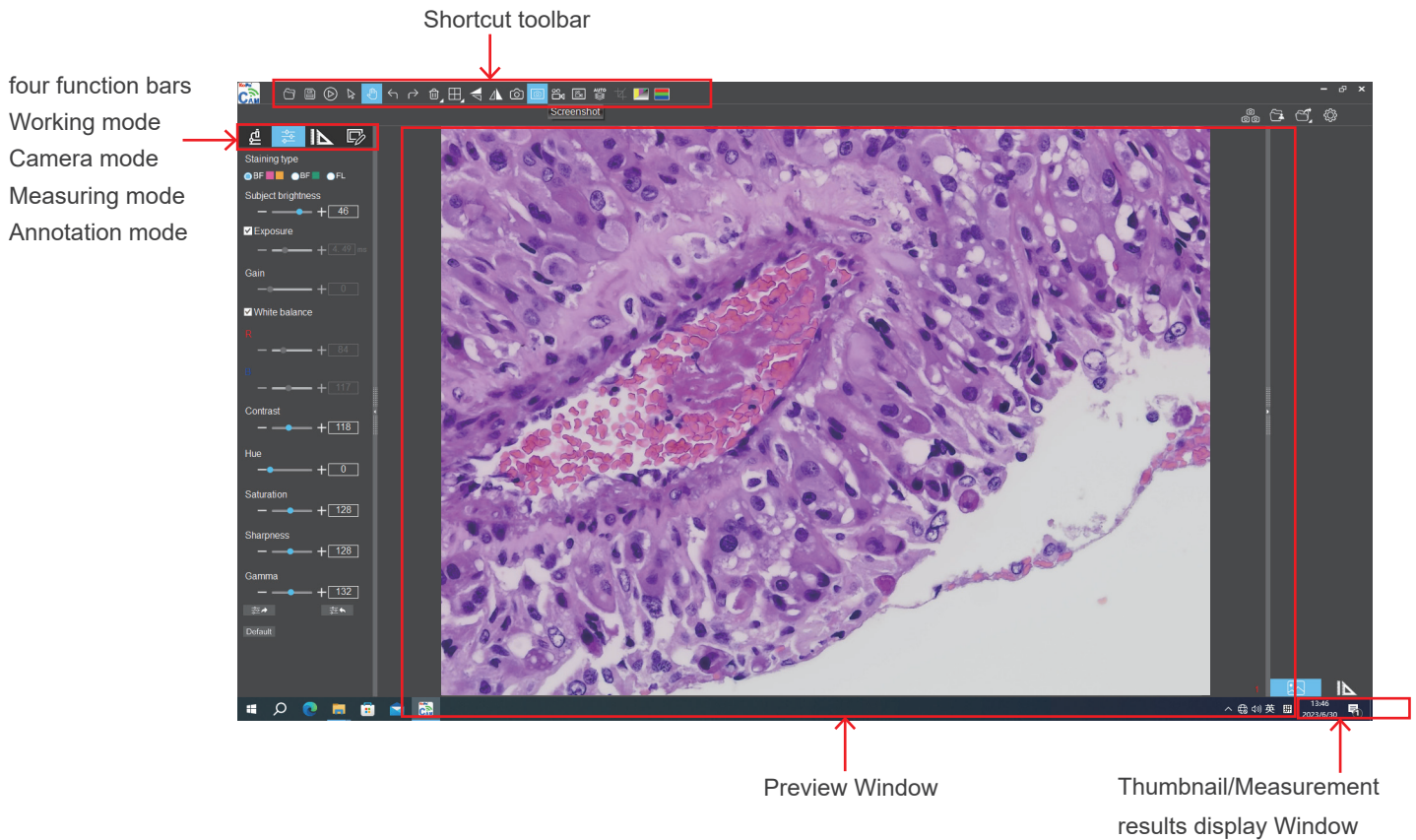











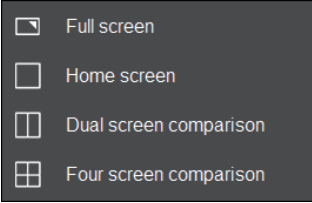

2.2 Shortcut toolbar

2.2.1 Shortcut tools



	Open document	Retrieve images from the local disk to the software.
	Save	After annotating the picture, adding text, etc., click the "Save" button to save the current annotation, text, etc
	Back to preview	If a still image is retrieved from the window, clicking this button will return the window to the preview dynamic picture.
	Select object	Select "objects" such as annotations, text, measurements, etc. for the next step, such as moving, deleting, etc. Support single selection or select them by drawing a big box around them.
	Drag	Use the mouse to drag the still image.
	Undo	Undoing the last operation on an "object".
	Redo	Redoing the last operation on an "object".

	Removal tool / Eraser tool	Delete or erase the selected "object" with a single click.
	Compare with multiple windows	 <p>Options of Full screen / Home screen / Dual screen comparison / Four screen comparison.</p>
	Flip	Flip the image on the currently selected screen.
	Mirror	Mirror the image on the currently selected screen.
	Take a picture	Take a picture on the currently selected screen.
	Screenshot	Screenshot on the entire computer desktop.
	Record	Record on the currently selected screen.
	Screen record	Screen record on the entire computer desktop.
	Automatic depth-of-field fusion function for high content images	Automatic extraction of the clearest areas of the captured image for fusion , take one picture, two archives.
	Core	Equal scale cropping of images.
	Combine channels	Assign fluorescence channels to selected images.
	Combined color images	Composite overlay of selected color fluorescence images.



2.2.2 Automatic depth-of-field fusion function for high content images

Automatic depth-of-field fusion function for high content images works with USB or WiFi connection. Break through the limitation of insufficient depth-of-field in high magnification objective lenses, and to adjust the focal length can obtain a greater depth of field, thus obtaining a sharper image than a real-time single-frame image, support taking one picture, two archives.

Operation steps:

Step 1. Click "  " button, a dual screen appears, the left screen is in line with the focal plane under the eyepiece, and the right screen is the result of high content fusion.

Step 2. Adjust the microscope coarse/fine focus knob, the depth-of-field fusion in real time on the right screen. If you switch the field of view midway, you can click "  " button to refresh.

Step 3. Click "  " button to automatically save two pictures on the left and right screen , close the current window to exit , click "  " button to enter the file manager and export pictures.

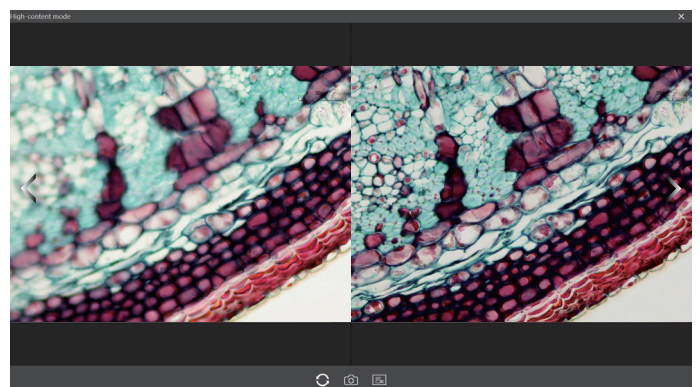

2.2.3 Combine channels

Fluorescent channels can be assigned quickly

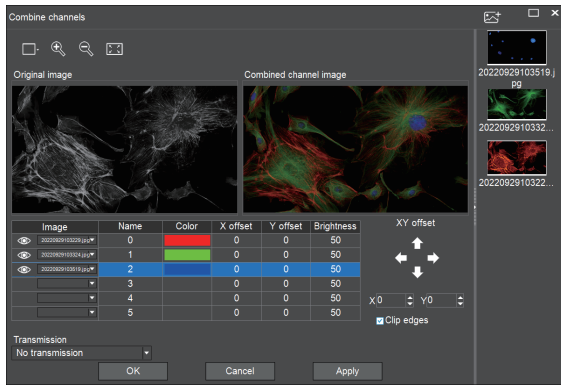

	Live image taking
	Preview window setting: double window to display original image and combine channels image separately, single window to display combine channels image only
	Image Zoom
	Image reduction
	Adapts to screen size
	Import images

Fluorescence channels can be specified for imported images (as shown in the figure below)

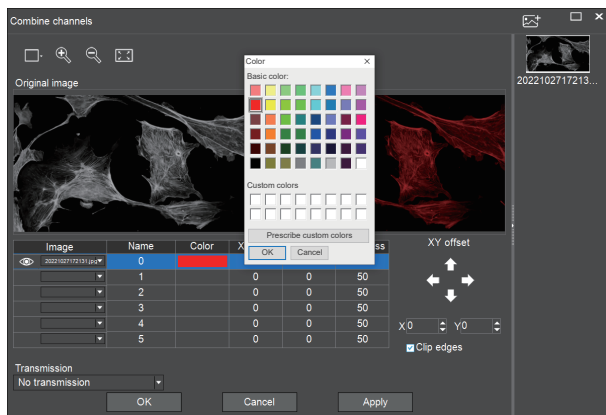

Allows direct input of X, Y, and brightness values for fine adjustment.

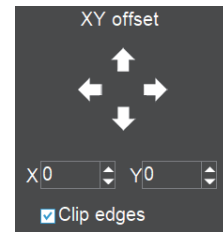

Note: Please import images with the same resolution, otherwise the image import will fail.

2.2.4 Combined color images

Color fluorescent images can be quickly combined.

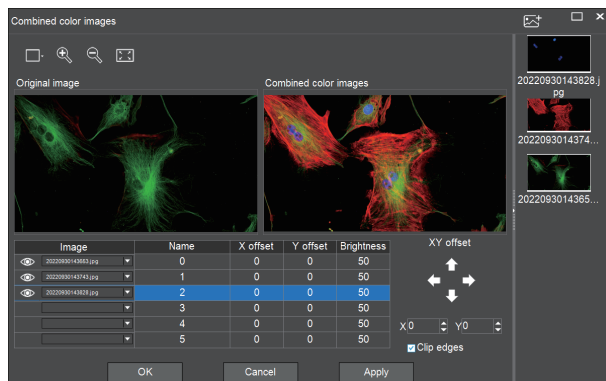

	Live image taking
	Preview window setting: double window to display original image and combine channels image separately, single window to display combine channels image only
	Image Zoom
	Image reduction
	Adapts to screen size
	Import images

Note: Please import images with the same resolution, otherwise the image import will fail.

Allows direct input of X, Y, and brightness values for fine adjustment.

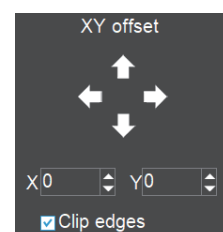

2.3 Working mode bar

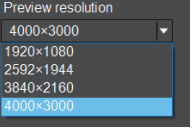
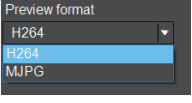

	Preview resolution	Any of the resolutions in the drop-down list can be set for preview.
	Preview format	<p>You can switch between MJPG and H264 preview formats.</p> <p>The advantage of H264 format is that the image quality is more transparent, but it requires a higher computer configuration.</p> <p>The advantage of MJPG format is that it requires a lower computer configuration, but the picture quality is not as good as H264.</p>

2.4 Camera property control

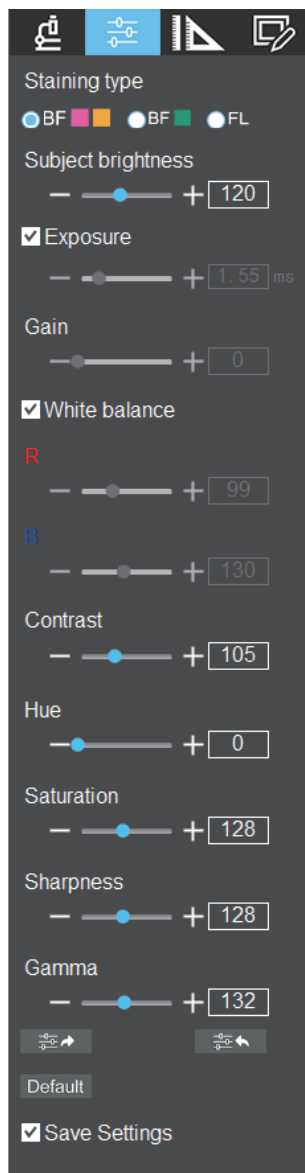

Adjust the corresponding image property parameters as needed to achieve the desired image effect.

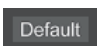

Staining type	<p>Users can select different exclusive types of stained pathology sections to obtain matching image effects and more accurate color reproduction.</p> <p>BF type 1: for bright-field, red or gold-based sections.</p> <p>BF type 2: for bright-field, cyan-dominated sections.</p> <p>FL type: for fluorescence observation.</p>
Brightness	Manually drag the adjustment bar to adjust the image brightness.
Exposure	When checked, the camera will automatically expose according to the environment used. When unchecked, manual exposure can be performed through the adjustment bar, supporting direct input of values in the box.
White Balance	<p>Manual white balance adjustment can be made through the adjustment bar, supporting direct input of values in the box.</p> <p>Click on "R" will restore the default value of the R channel alone.</p> <p>Click on "B" will restore the default value of the B channel alone</p>
Gain	Manually drag the adjustment bar to adjust the image gain. Support for entering values directly in the box. Click on "Gain" will restore the default value of gain alone.
Contrast	<p>Manually drag the adjustment bar to adjust the image contrast. Support for entering values directly in the box.</p> <p>Click on "Contrast" will restore the default value of contrast alone</p>
Hue	Manually drag the adjustment bar to adjust the image hue. Support for entering values directly in the box. Click on "Hue" will restore the default value of hue alone.
Saturation	Manually drag the adjustment bar to adjust the image saturation. Support for entering values directly in the box. Click on "Saturation" will restore the default value of saturation alone.
Sharpness	Manually drag the adjustment bar to adjust the image sharpness. Support for entering values directly in the box. Click on "Sharpness" will restore the default value of sharpness alone.
Gamma	Manually drag the adjustment bar to adjust the image gamma. Support for entering values directly in the box. Click on "Gamma" will restore the default value of gamma alone.
Export image properties	 Exporting image properties to local disk.
Import image properties	 Import image properties from local disk.
Restore Default values	 Restore all image property parameters to their default values.

2.5 Measuring tools



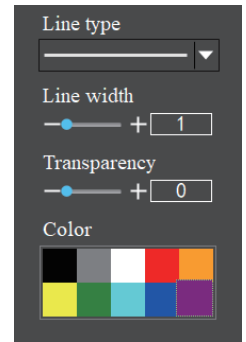

Provides calibration function as well as measurement function for dynamic or still image in the preview window.

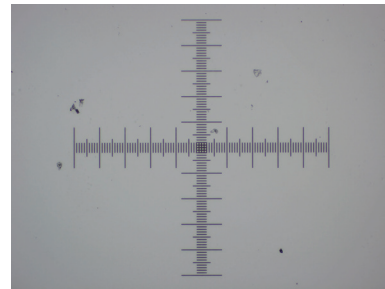

2.5.1 Calibration

Step 1: Please place the micrometer under the microscope, the example below uses a micrometer with $1DV = 0.01mm$.



Step 2: Click on “” to bring up the calibration table as shown below.

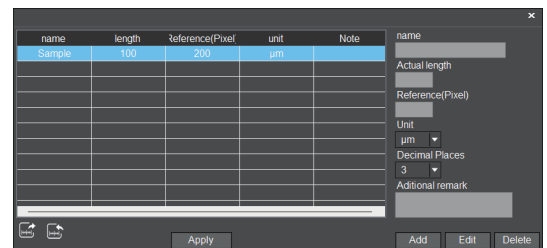

Step 3: When using the mouse to draw a straight line on the micrometer image and setting the scale length, selecting a longer scale length will give more accurate results. For example, selecting 10 small scale lengths will give you more accuracy than selecting only 1 scale length. After releasing the mouse, the image value of the line drawn with the mouse will be automatically updated in the "Benchmark" of the calibration table, as shown in the following figure.

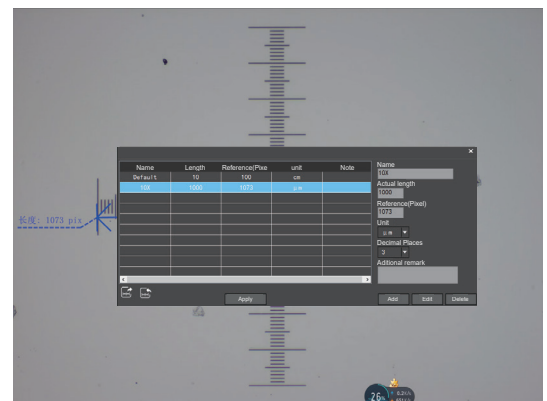

Step 4: Enter a name in the calibration table, such as 10X.

In the calibration table, enter the actual length that just drawn on the micrometer, for example, the sample figure is drawn 100 DV, that is, 1mm, or 1000µm, then enter the "actual length" box to fill in the specified 1000, "unit" select "µm". Then click "Add" to add this calibration value to the calibration table to be used. Add the calibration value for other objectives of different magnifications in this way.

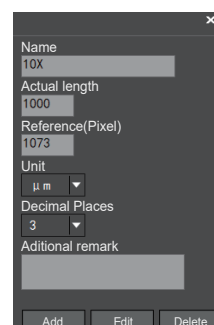

Notes.

- ① "Add": The information in the right box will be added to the list on the left.
- ② "Edit": The calibration value selected in the left list will be modified.
- ③ "Delete": The calibration value selected in the left list will be deleted.
- ④ "Apply": The calibration value selected in the left list will be called.

2.5.2 Select measurement tool for measurement

Firstly, select the calibration value according to the actual objective used in the calibration table and click on "Apply". The following figure shows.:

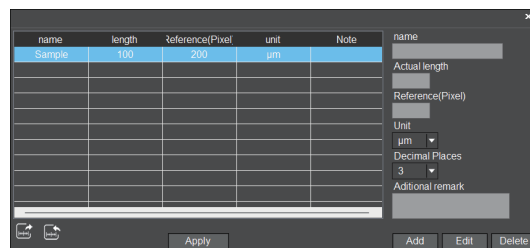

Then select the measurement tools to measurement as follows:

	Linear distance measurement		Concentric circle measurement
	Circular measurement		Concentric radius circle center distance drawing circle measurement
	Rectangle measurement		Ring measurement
	Three-point angle measurement		Manual count
	Parallel line spacing measurement		Font
	Center distance measurement of double parallel lines		Scale mark
	Polyline measurement		Scale bar
	Polygon measurement		Line type
	Arc measurement		
	Three-point vertical line measurement		
	Four-point angle measurement		line width
	Ellipse measurement		Transparency
	Circle radius measurement		Colour
	Three point drawing circle measurement		

The results of each measurement will be displayed on the right side of the software. The user can export the measurement results.

Click the export tool  in the upper right display bar to export data and images to PDF, Word, Excel, printer and mail (Outlook only). Export to PDF, printer and mail functions are only available for still images.

Select Export to Word, as shown below: Enter file name, select path, and click "Save".

The exported documents are as follows:

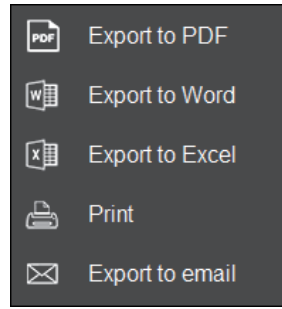



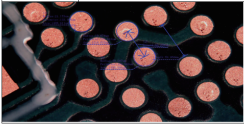



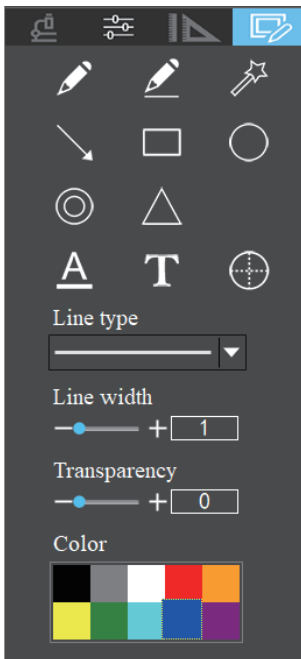



Serial No.	Measure item	Measured value
1	Circular measurement	Radius=21.175 um Perimeter=133.046 um Area=1408.611 um ²
2	Concentric circle measurement	Radius1=19.674 um Perimeter1=123.616 um Area1=1216.025 um ² Length=60.056 um Radius2=19.507 um Perimeter2=122.569 um Area2=1195.504 um ²
3	Linear distance measurement	Length=76.050 um



2.6 Drawing tools

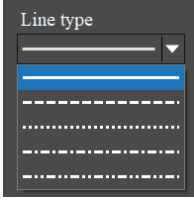
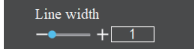
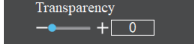
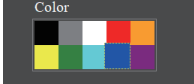

	Pencil
	Straight line
	Highlighter
	Single arrow straight line
	Rectangle
	Oval
	Isosceles triangle
	Concentric circles
	Font
	Insert text
	Line type
	Line width
	Transparency
	Colour

2.7 Thumbnail toolbar

Right-clicking on a thumbnail will display the action menu as shown in the figure below.

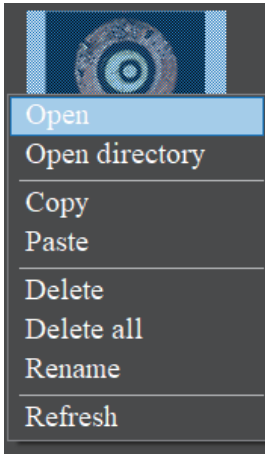

Open: Open the image in the software default way.

Open directory: Open the directory where the selected image is located.

Copy: Copy the currently selected image.

Paste: Paste the image that has been copied. (Note: Paste can only be done within the thumbnail toolbar).

Delete: Permanently delete the selected image and permanently delete the source file.

One-click deletion: permanently delete all thumbnails and permanently delete the source files.

Rename: Rename the selected image.

Refresh: Refresh the current image thumbnail area.

2.8 Software setup

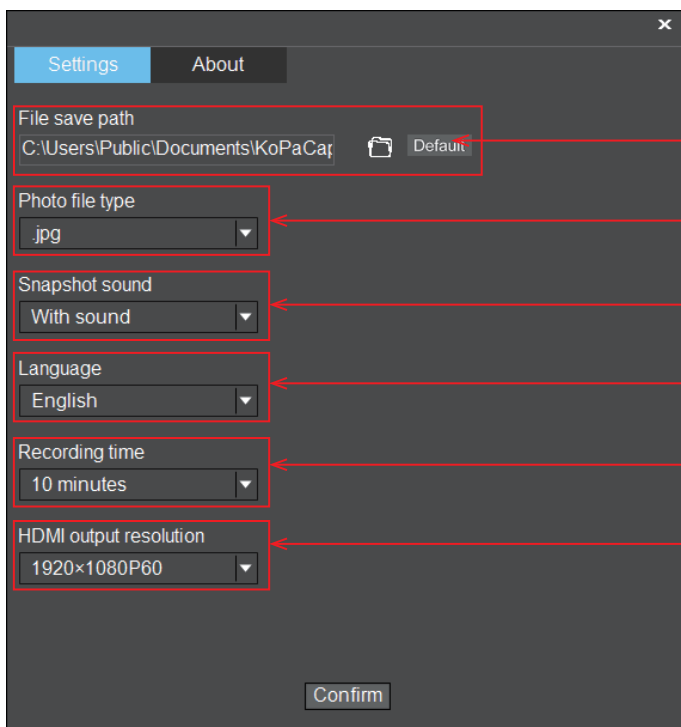

Support access / modify / restore default file save path.

Support modifying image saving format: JPG, BMP, TIFF, PNG.

Support modifying the camera sound as off or on.

Support for modifying software interface language.

Support modifying the default maximum single recording time.

Support for modifying the image resolution of an external HDMI display. (This function is only valid for cameras with HDMI output).